



For Non-Armored Cable

(303) Stainless Steel (INOX) Cable Glands for Hazardous Duty Locations, Low Temperature, Nylon/PVDF Clamping Spline with Buna-N/ FPM Inserts, V0, NEMA 6, 150 PSIG, IP 68/69K, 10 BAR

Part Numbers			Cable Range	Thread Type & Size	Dimensions in Inches (mm)			
-4°F to 203°F (-20°C to 95°C)	-78°F to 203°F (-60°C to 95°C)	-4°F to 266°F (-20°C to 130°C)			A	B	C	F
			Inches (mm)	Page 59 for Thread Specs	Clearance Hole +.01" (+.25 mm)	Body Length (Dome)	Thread Length	Wrench Flats
CD12MA-SX	CC12MA-SX	CD12MA-SX-V	.12 - .26 (3 - 6.5)	M12 x 1.5	.47 (12)	.75 (19)	.26 (6.5)	.55 (14)
CD12MR-SX	CC12MR-SX	CD12MR-SX-V	.08 - .20 (2 - 5)					
CD17MA-SX	CC17MA-SX	CD17MA-SX-V	.20 - .39 (5 - 10)	M16 x 1.5	.63 (16)	.87 (22)	.24 (6)	.87 (22)
CD17MR-SX	CC17MR-SX	CD17MR-SX-V	.12 - .28 (3 - 7)					
CD22MA-SX	CC22MA-SX	CD22MA-SX-V	.39 - .55 (10 - 14)	M20 x 1.5	.79 (20)	.91 (23)	.24 (6)	.94 (24)
CD22MR-SX	CC22MR-SX	CD22MR-SX-V	.28 - .47 (7 - 12)					
CD25MA-SX	CC25MA-SX	CD25MA-SX-V	.51 - .71 (13 - 18)	M25 x 1.5	.98 (25)	.94 (24)	.28 (7)	1.18 (30)
CD25MR-SX	CC25MR-SX	CD25MR-SX-V	.35 - .63 (9 - 16)					
CD32MA-SX	CC32MA-SX	CD32MA-SX-V	.79 - .98 (20 - 25)	M32 x 1.5	1.26 (32)	1.14 (29)	.31 (8)	1.61 (41)
CD32MR-SX	CC32MR-SX	CD32MR-SX-V	.51 - .79 (13 - 20)					
CD40MA-SX	CC40MA-SX	CD40MA-SX-V	.87 - 1.26 (22 - 32)	M40 x 1.5	1.57 (40)	1.38 (35)	.31 (8)	1.97 (50)
CD40MR-SX	CC40MR-SX	CD40MR-SX-V	.79 - 1.02 (20 - 26)					
CD07AA-SX	CC07AA-SX	CD07AA-SX-V	.12 - .26 (3 - 6.5)	PG 7	.49 (12.5)	.75 (19)	.20 (5)	.55 (14)
CD07AR-SX	CC07AR-SX	CD07AR-SX-V	.08 - .20 (2 - 5)					
CD09AA-SX	CC09AA-SX	CD09AA-SX-V	.16 - .31 (4 - 8)	PG 9	.60 (15.2)	.83 (21)	.24 (6)	.67 (17)
CD09AR-SX	CC09AR-SX	CD09AR-SX-V	.08 - .24 (2 - 6)					
CD11AA-SX	CC11AA-SX	CD11AA-SX-V	.20 - .39 (5 - 10)	PG 11	.73 (18.5)	.87 (22)	.24 (6)	.87 (22)
CD11AR-SX	CC11AR-SX	CD11AR-SX-V	.12 - .28 (3 - 7)					
CD13AA-SX	CC13AA-SX	CD13AA-SX-V	.24 - .47 (6 - 12)	PG 13	.80 (20.3)	.94 (24)	.24 (6)	.87 (22)
CD13AR-SX	CC13AR-SX	CD13AR-SX-V	.20 - .35 (5 - 9)					
CD16AA-SX	CC16AA-SX	CD16AA-SX-V	.39 - .55 (10 - 14)	PG 16	.89 (22.5)	.91 (23)	.24 (6)	.94 (24)
CD16AR-SX	CC16AR-SX	CD16AR-SX-V	.28 - .47 (7 - 12)					
CD21AA-SX	CC21AA-SX	CD21AA-SX-V	.51 - .71 (13 - 18)	PG 21	1.12 (28.4)	.94 (24)	.28 (7)	1.18 (30)
CD21AR-SX	CC21AR-SX	CD21AR-SX-V	.35 - .63 (9 - 16)					
CD29AA-SX	CC29AA-SX	CD29AA-SX-V	.79 - .98 (20 - 25)	PG 29	1.47 (37.3)	1.14 (29)	.31 (8)	1.61 (41)
CD29AR-SX	CC29AR-SX	CD29AR-SX-V	.51 - .79 (13 - 20)					
CD36AA-SX	CC36AA-SX	CD36AA-SX-V	.87 - 1.26 (22 - 32)	PG 36	1.85 (47)	1.38 (35)	.31 (8)	1.97 (50)
CD36AR-SX	CC36AR-SX	CD36AR-SX-V	.79 - 1.02 (20 - 26)					

*CE & CSA apply to all SX style cable glands.

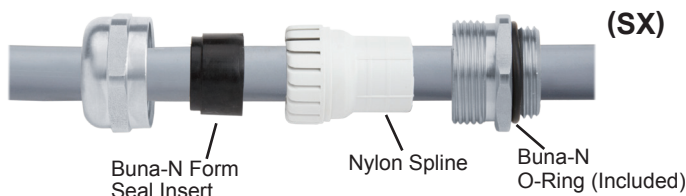

Also available 316L Stainless Steel
e.g.- CDxxxx-6X & CDxxxx-6X-V
See more information online

Nylon is Ideal for Lower Temperature Applications!

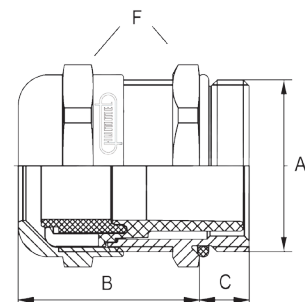
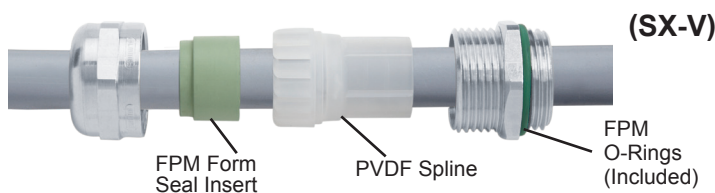

PVDF is Ideal for Higher Temperature Applications!